

Non-Contact Interlock/Position Switch

Applications

- Semi-conductor Equipment
- Packaging Machinery
- Farm Implement
- Conveyers
- Position Sensing
- Economical Proximity Switch Replacement

General Specifications

Enclosure	Stainless Steel Threaded Barrel with 2 Jam Nuts
Dimensions	M8 dia. x 1.25 Thread x 50mm Long
Temperature Range	-40°F to 180°F (-40°C to 80°C)
Environmental	Hermetically Sealed Contact Switch Encapsulated in Polyurethane
NEMA Rating	1, 2, 3, 4X, 5, 6, 12, 12K
Protection Class	IP 67
Response Time	1 msec
Life Cycles	100,000 Under Full Load; Up to 200,000,000 Under Dry Circuit
Lead Types/O.D.	22/2 Jacketed / 0.24" (0.62cm)
UL/CSA	All Models

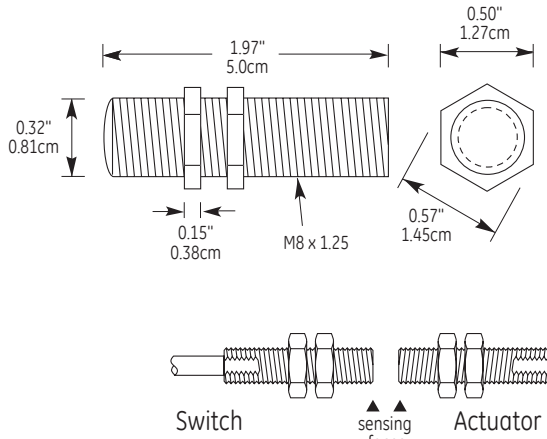

INTERLOCK SWITCH 100 SERIES

Order Information	Electrical Specifications				ACTUATOR SOLD SEPARATELY				
Part Number	Contact ¹ Config.	Load Rating AC	Load Rating DC	Switching Voltage, Max. AC	Switching Voltage, Max. DC	Switching Current, Max. AC	Switching Current, Max. DC	Contact Resistance	Lead Length
128C-6N-06J	N.O.	25VA	25W	120V(@0.2A)	120V(@0.2A)	0.7A (@35V)	1.0A (@25V)	0.2 Ohms	6'(1.8m)
128C-6N-12J	N.O.	25VA	25W	120V(@0.2A)	120V(@0.2A)	0.7A (@35V)	1.0A (@25V)	0.2 Ohms	12'(3.6m)

Warning— Each electrical rating is an individual maximum and cannot be exceeded!

¹ Configuration with actuator away from the switch

Sense range ²			
Actuator Options	Make, Min.	Break, Max.	Actuator Description
128C-U	0.15	1.00	Alnico Magnet in M8x1.25x50 stainless steel threaded barrel w/2 jam nuts
129-X	0.35	1.35	Alnico Magnet in M12x1x70 stainless steel threaded barrel w/2 panel nuts
1057	0.85	2.15	Bare Alnico Magnet 3/8" dia. x 1-1/2" long
1830	0.15	0.65	Rare Earth 0.375" dia. x 0.12" thick w/#4 countersink hole
IND1835	0.40	1.00	Rare Earth 0.6" dia. x 0.12" thick w/#4 countersink hole

² Proximity of ferrous materials usually reduces sense range — typically by 50%. The shape and type of material cause a wide diversity of effects. Testing is required to determine actual sense range for specific applications.

